

Key Features

- Air Bearing Rotary Table with Direct Drive
- High Load Capacity
- Radial Runout < 0.15 µm
- 1,100 U/min in Standard Version
- 1 Vpp or with Interpolation (5x, 10x, 100x)



Rotary Table EZ-0570

Concept and Design

Due to its high load capacity (up to 2,200 N axial/radial), the EZ-0570 rotary stage is particularly suitable for high precision positioning of heavy loads up to 40 kg. Among other applications, the rotary table is preferably used for measuring tasks with non-contact measuring systems. Equipped with a powerful iron-core torque motor, dynamic applications can also be realized. To further reduce axial and radial error motion, the rotary table can also be operated with an ironless motor.

The measuring system (Numerik RIK4) with 18,000 lines can optionally be supplied with an interpolation factor of 5, 10, 50 or 100.

The rotor is magnetically preloaded, it is clamped to the housing when the air supply is switched off and remains fixed in its position.

There are no restrictions with regard to the installation position. Due to the materials used and because air

bearings are basically operated without lubricants, the rotary table is suitable for use in clean rooms.

Applications

High-precision positioning and measuring systems, inspection technology, testing systems, applications with high demands on synchronization and/or repeatability of positioning.

Drive Control

We offer the rotary table EZ-0570 with the following drive controllers:

- Kollmorgen AKD P00606
- Kollmorgen Servostar S300 / S700
- ACS Controller

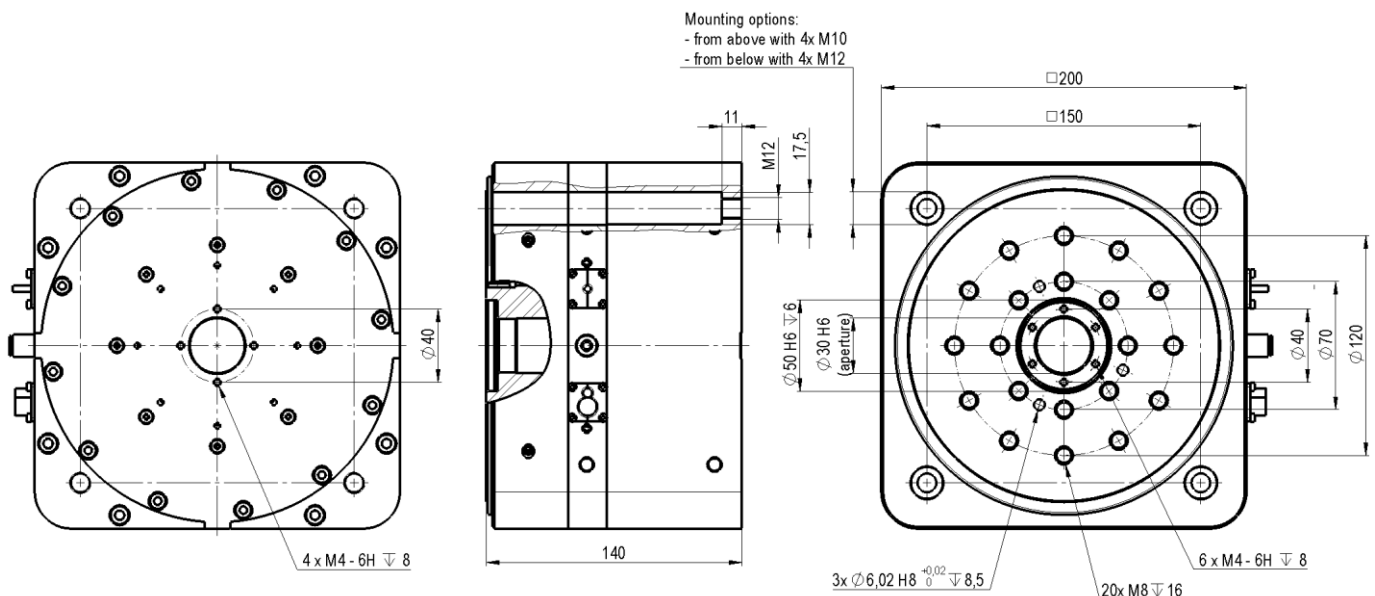

Specifications

Type	Unit	Value
Turning Range	°	> 360 (unlimited)
Error Motion axial (in the center)	µm	< 0.15
Error Motion radial (at 20 mm height)	µm	< 0.15
Axial Runout (along radius 35 mm)	µm	2
Repeatability (uncompensated)	arcsec	± 1.5
Angular Accuracy (compensated)	arcsec	± 15
Max. Speed ¹⁾	rpm	1,100
Mechanical Data		
Mounting Position		unrestricted
Length x Width x Height	mm	200 x 200 x 140
Moving Mass (rotor)	kg	3
Total Mass	kg	15
Max. Load Capacity axial	N	2,200
Nominal Load Capacity axial push/pull	N	1,600
Max. Load Capacity radial	N	2,200
Nominal Load Capacity radial	N	1,600
Stiffness axial	N/µm	280
Stiffness radial	N/µm	100
Resistance Against Tilt	Nm/µrad	0.58
Max. Moment of Tilt	Nm	70
Inertial Moment	kg*m ²	0.019
Material		aluminum hardcoat/anodized
Encoder		
Type		incremental
Lines per Revolution		9,000 / 18,000
Output Signal		1Vpp / RS422
Interpolation Options		5, 10, 50, 100-fold
Drive		
Type		synchronous, iron-core
Intermediate Circuit Voltage	V _{DC}	max. 600
Nominal/Peak Torque	Nm	10 / 30
Nominal/Peak Current	A _{rms}	3.4 / 10
Interfaces and Environment		
Supply Pressure	bar	5
Air Consumption	Sl/min	ca. 18
Cable Length	m	1
Clean Room Suitability		applicable
Drive Control		
Standard		Kollmorgen AKD P00606 / Servostar S300
High End		ACS Controller

1) depending on interpolation value

Subject to technical modifications and typographical errors.