

Key Features

- Mounting Surface Slide 59.5 x 15 mm (l x w)
- Payload up to 500 g
- Without Measuring System
- Without Drive
- High Positioning Accuracy
- Compact Design
- Longer Guide Rails on Request



Air Bearing Linear Axis

Concept and Design

The linear axis consists of a guide rail and a slide. The slide is preloaded by magnetic force and, apart from a small Newtonian force, moves without friction. Due to the friction-free movement and the compact design the axis is ideal for beam guidance.

The air-bearing axis is designed for small to medium-sized strokes with loads of up to approx. 500 g.

The guide rail is made of stainless steel, the slide is made of hardcoated aluminium.

The axis shown in this data sheet is without drive and measuring system, but can easily be equipped with a voice coil motor and measuring system.

The linear axis can be extended by a second, mirror-inverted slide. The guide rail can be adjusted in length.

Applications

Beam guidance, positioning of optical components, mirror positioning, AOI (automatic optical inspection) inspection technology, photovoltaic production.

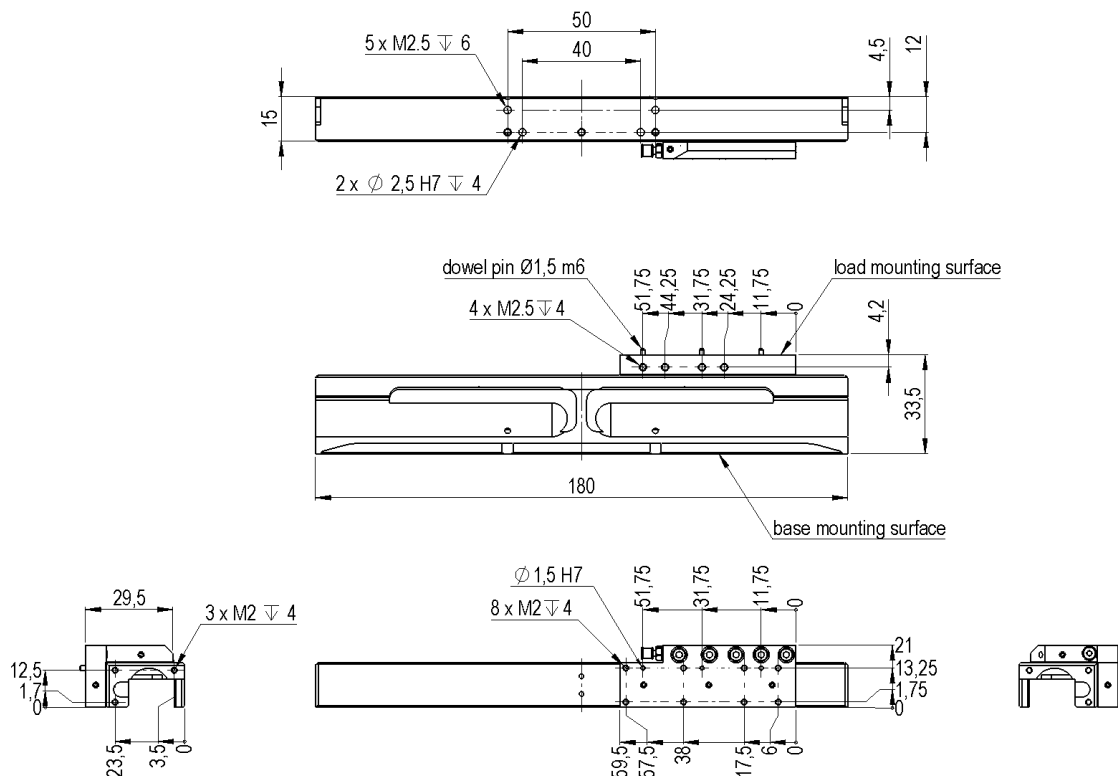

Specifications

Type	Unit	Value
Stroke ¹⁾	mm	15
Vertical/Horiz. Straightness (XTZ/XTY)	µm	< ±1
Mechanical Data	Unit	Value
Mounting Position		unrestricted
Dimension Slide Mounting Surface LxW	mm	59.5 x 15
Dimension Guide Rail with Slide LxWxH	mm	180 x 21 x 33.5
Load Capacity vertical (Z) push/pull	N	100
Load Capacity lateral (Y)	N	120
Stiffness	N/µm	ca. 20
Moving Mass (slide)	g	22
Total Mass	g	354
Encoder		Value
Type ²⁾		without encoder/measuring system
Drive		Value
Type ²⁾		without drive
Interfaces and Environment	Unit	Value
Air Consumption	Sl/min	9
Supply Pressure	bar	5
MTBF	h	> 20,000
Limit Switch		without
Clean Room Suitability		applicable

1) standard version, other strokes are possible on request

2) additional equipment with a voice coil motor and measuring system is possible on request

Subject to technical modifications and typographical errors.

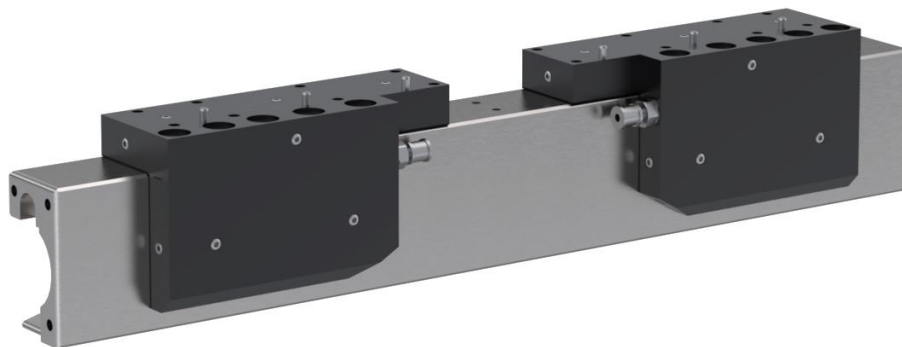

Design example: Axis with 2 air-bearing slides